

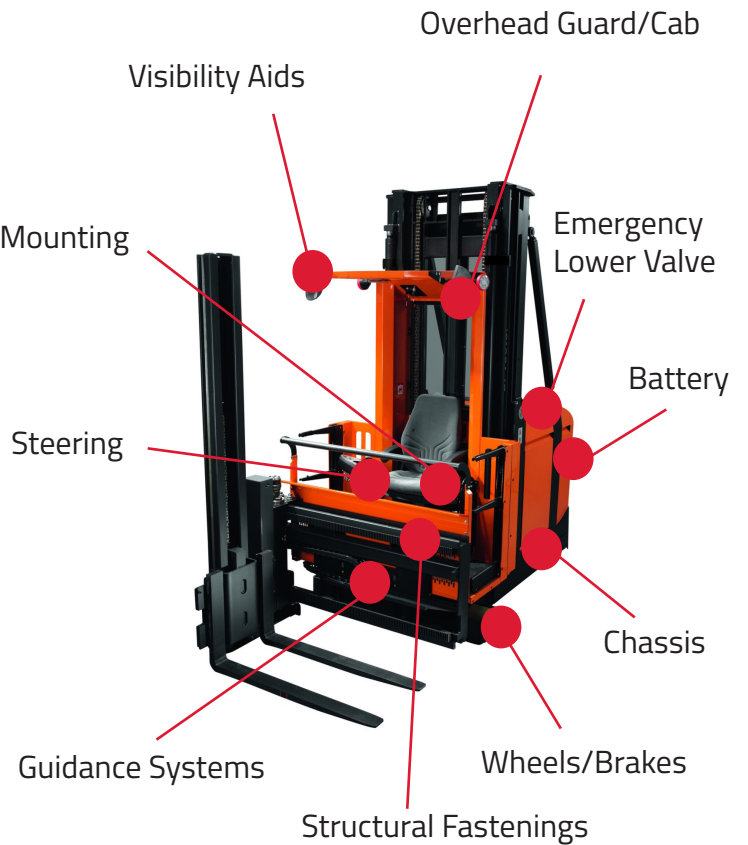

THOROUGH EXAMINATION

WHAT IS COVERED? VNA TRUCKS

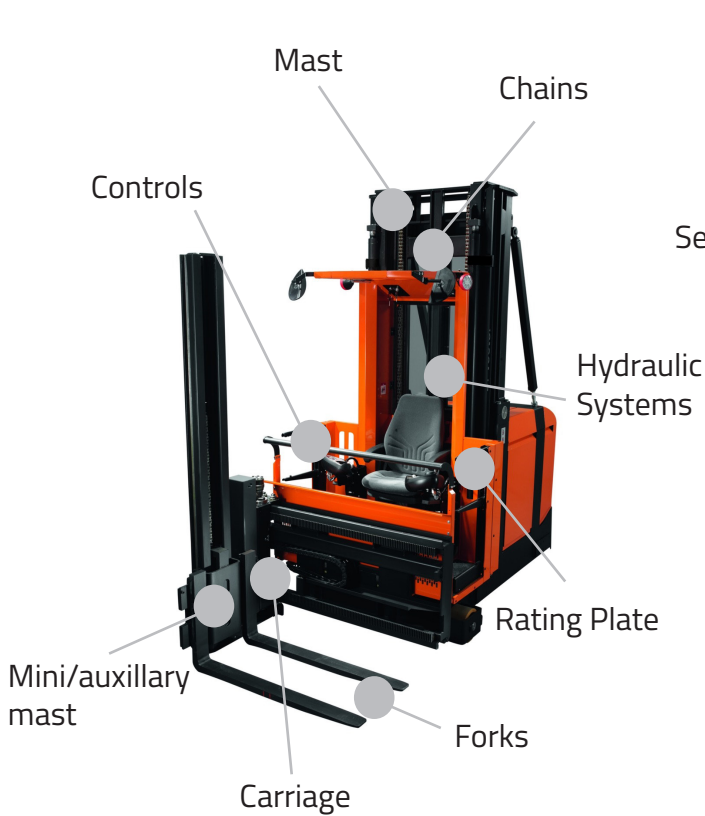

LOLER (Lifting Operations & Lifting Equipment Regulations 1998)

LOLER 98 relates to the safe use of mechanical handling and lifting equipment and is contained in the lifting equipment regulations 1998. This legislation is concerned with the main risks associated with the use of equipment which include equipment failure, incorrect use of equipment, danger to people in the operating area and danger to the operator.

PUWER (Provision & Use of Work Equipment Regulations 1998)

All mechanical handling and lifting equipment is classed as work equipment and is subject to PUWER regulations. They require: the inspection and maintenance of the equipment, the provision of information, instruction and training, the marking of controls, that mobile work equipment for carry people is suitable, protection from rolling over, facilities to prevent unauthorised use of the equipment, the provision of lifting equipment, where necessary and the provision of devices to improve vision, where necessary.

CONTACT US TO BOOK YOUR THOROUGH EXAMINATION:
0370 850 1409 / WWW.TOYOTA-FORKLIFTS.CO.UK

TOYOTA

MATERIAL HANDLING